

TwinLED

The **TwinLED** projector luminaires offer simple and effective emergency lighting from high efficiency LED projectors.

The **TwinLED** units feature a novel lens system offering fine optical control resulting in high intensity beam patterns to ensure effective area illumination.

The 2 x 3 Watt projector heads provide excellent performance and full photometry (LDT files) can be supplied upon request.

The **TwinLED** units are supplied with high quality 3.6 Volt 4Ah NiCd batteries.

OPERATION

The **TwinLED** units are supplied as standard with Non-maintained operation with Polycarbonate heads, lenses and main enclosure.

The 2 x 3Watt TwinLED provides 3 hour duration from the integral Nickel Cadmium (NiCd) batteries and fully complies with the requirements of EN60598.2.22

DALI/Self-Test Options:

The **TwinLED** luminaires can be specified with integral DALI/Self-Test gear providing automatic Self -Test in accordance with BSEN62034 or fully interoperable DALI operation when connected to a DALI control system.

NOTE: **TwinLED** luminaires can be equipped with **SurePath BLE** Bluetooth addressable Gateway modules. [See Data Sheet.](#)



TLD/NM3



GENERAL DETAILS

Product	Twin LED Projector
Light Source	Each head: 7 white LEDs
Luminaire Lumens	2 x 380lm
Construction	Polycarbonate heads, lenses and enclosure
Dimensions	275mm (W) x 155mm box: 300mm total (H) x 55mm (D)
Cable Entry	20mm knock-outs in one end and back

Emergency Lighting Products Limited
Parbrook House, Cillmans Industrial Estate,
Natts Lane Billingshurst, West Sussex RH14 9EZ

Telephone: +44 (0) 1403 786601
Fax: +44 (0) 1403 786602
e-mail: sales@elp.uk.com

Safe in the knowledge
elp.uk.com

TwinLED

SPECIFICATION

Light source	Two 3W LED heads
Colour temperature	5000K
Light output	2 x 380lm
IP Rating	IP20
Ambient temperature (Ta)	0°C - 25°C
Insulation Class	Class II
Supply	230V ~ 50Hz
Supply power	2.9W
Charge power (typical)	2.9W
Weight	1.4kg (max.)

PERFORMANCE

Full photometry (.LDT file) available.

Typical example:

TLD/NM3 wall mounted 2.5m high can be spaced 25 metres apart to achieve 1Lux on a corridor centre line.

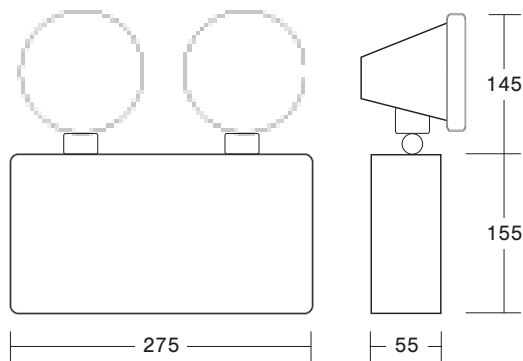

ORDER CODES

Description

TLD/NM3	Non-maintained with 3-hour emergency
TLD/NM3/DALI	Non-maintained with 3-hour DALI/self-test emergency
OPTIONS:	/BLE Wireless DALI emergency

Emergency Lighting Products Limited
Parbrook House, Cillmans Industrial Estate,
Natts Lane Billingshurst, West Sussex RH14 9EZ

Telephone: +44 (0) 1403 786601
Fax: +44 (0) 1403 786602
e-mail: sales@elp.uk.com

Safe in the knowledge
elp.uk.com