

# Access

The **Access** unit offers a simple method of providing discreet emergency lighting in areas that require a surface mounted or recessed self-contained solution.

Supplied with a 'clip-in' symmetrical wide angle lens or asymmetrical 'corridor' lens for escape routes (both supplied) the **Access** downlight simply requires a permanent 230Volt supply to provide effective non-maintained emergency lighting with 3hour duration.

## Standard DALI/Self-Test

Incorporating tried and tested emergency driver technology from the ELP **proSeries**, the **Access** downlight offers self-contained, non-maintained operation emergency lighting with integral automatic Self-Test or DALI communication from a single product.

The enclosure may be surface mounted or recessed into the supporting surface. With either mounting option the **Access** is both discreet and attractive.

Finished in white or black fire retardant plastic the **Access** blends in with the other architectural furniture.

The excellent performance allows the units to be mounted at very wide spacings making installation simple and cost effective. **NOTE: Access** luminaires can be equipped with **SurePath BLE** Bluetooth addressable Gateway modules. [See Data Sheet.](#)

## SPECIFICATION

The surface or recessed mounting enclosure houses an 'intelligent' proSeries DALI/Self-Test LED driver and a Lithium Iron Phosphate (LiFePO<sub>4</sub>) battery. A Nichia '3Watt' high power white LED is mounted in the fascia plate in conjunction with a choice of wide angle or 'corridor' distribution lens.

The Lithium Iron Phosphate battery technology incorporates smart charging which provides energy saving over other traditional battery technologies. In addition, the Lithium Iron Phosphate batteries offer long life (up to 8 years).

Fully integrated components and the latest software ensure that the Access luminaire can be connected to any approved DALI control system. When the mains supply is initially connected, the **Access** circuit initiates the Self-Test commissioning mode and then activates the weekly and annual test routine starting at random times to ensure tests do not get carried out simultaneously in the same areas. Faults such as charge failure, battery failure, etc. will be indicated locally by a bi-colour LED.

The Access luminaire will continually be prepared for a DALI signal even when operating in Self-Test mode. If a DALI signal is received the Self-Test mode will be disabled and the circuit will adopt full DALI mode.



Surface



Operation indicator LED shines through a skin in housing plastic



**Emergency Lighting Products Limited**  
Parbrook House, Cillmans Industrial Estate,  
Natts Lane Billingshurst, West Sussex RH14 9EZ

Telephone: +44 (0) 1403 786601  
Fax: +44 (0) 1403 786602  
e-mail: sales@elp.uk.com

**Safe in the knowledge**  
[elp.uk.com](http://elp.uk.com)

**Self-contained Surface/Recessed Downlight**

# Access

OPERATION	Subject	Plastic housing
<b>Environmental</b>	Protection against electric shock	Class II
	Ingress protection	IP40
	Rated operating ambient temperature	0°C to 25°C
	Surface and recess mounting	Flammable surfaces and covered
<b>Mains operation</b>	Rated voltage supply	220/240V AC
	Mains frequency	50/60Hz
	Mains supply current	20mA
<b>Emergency operation</b>	Emergency duration	3 hours
	Battery recharge period	<24 hours
	Battery charging	Intelligent constant voltage
	Battery discharge current – nominal	370mA
	Lumen output	260lm (max)
<b>Mechanical</b>	Integral test routine	EN62034/DALI
	Dimensions (Surface)	142mm dia x 43mm (h)
	Dimensions (Recessed)	130mm dia cut-out x 43mm (h)
	Mains input	unswitched L&N

## ACCESS – Emergency Lighting Spacings

Mounting height Hm (m)	ACCESS/C		ACCESS/WIDE	
	Spacing (m) min 0.5Lux open area	Spacing (m) min 1Lux escape	Spacing (m) min 0.5Lux open area	Spacing (m) min 1Lux escape
2.0	n/a	14.0	13.9	12.8
2.5	n/a	15.3	15.1	14.0
3.0	n/a	16.5	14.8	13.6

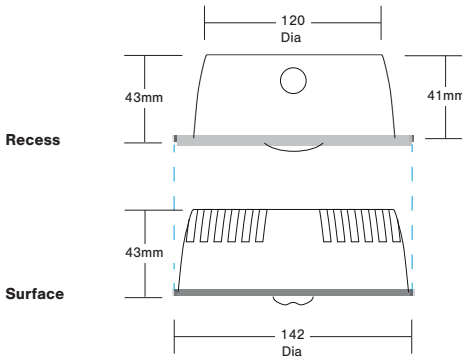

ORDER CODES	Description
<b>AC2/NM3/DALI/ST</b>	White surface/recessed mounted luminaire, self-contained DALI/Self-Test NM3 supplied with 'Corridor' and wide angle lens
<b>AC2/NM3/DALI/ST/BK</b>	Black surface/recessed mounted luminaire, self-contained DALI/Self-Test NM3 supplied with 'Corridor' and wide angle lens
<b>AC2/NM3/MT/WH</b>	White surface/recessed mounted luminaire, self-contained manual-test NM3 supplied with 'Corridor' and wide angle lens
<b>AC2/NM3/MT/BK</b>	Black surface/recessed mounted luminaire, self-contained manual-test NM3 supplied with 'Corridor' and wide angle lens
OPTIONS:	/BLE Wireless DALI emergency

**Emergency Lighting Products Limited**  
 Parbrook House, Cillmans Industrial Estate,  
 Natts Lane Billingshurst, West Sussex RH14 9EZ

Telephone: +44 (0) 1403 786601  
 Fax: +44 (0) 1403 786602  
 e-mail: sales@elp.uk.com

**Safe in the knowledge**  
 elp.uk.com